

# GRAND SLIM

SLIMTEK SERIES | PANORAMIC SLIDING DOORS

A COMBINATION OF FUNCTION AND DESIGN  
SETTING A NEW STANDARD FOR PANORAMIC PUSH-PULL

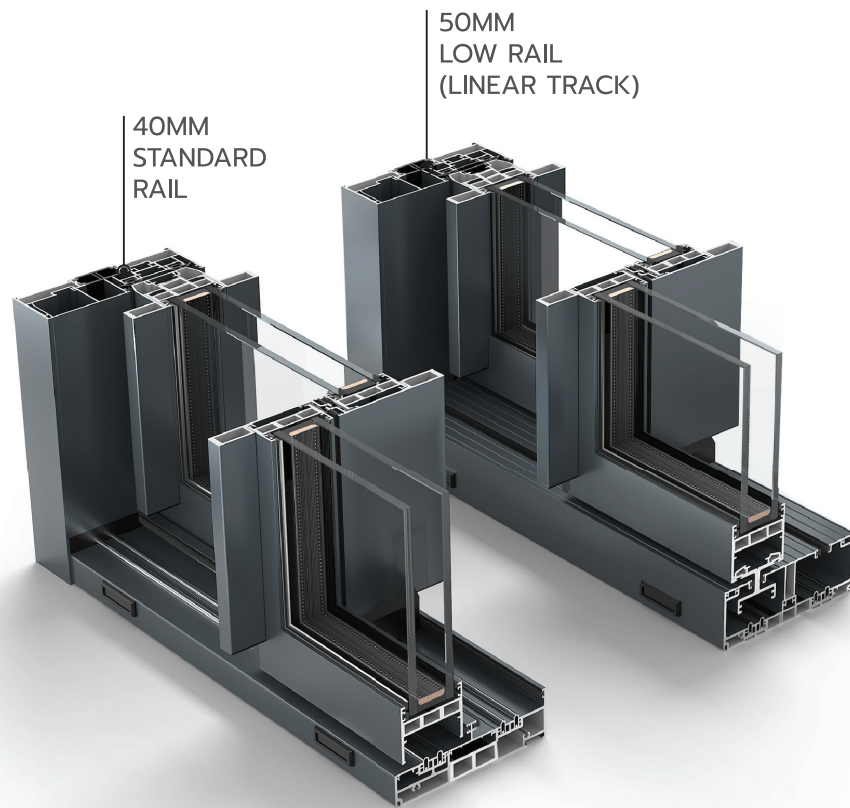



**A COMBINATION OF  
FUNCTION AND DESIGN  
SETTING A NEW STANDARD  
FOR PANORAMIC PUSH-PULL**

IN RECENT YEARS, THE PANORAMIC SLIDING SYSTEM HAS BEEN FAVORED BY DESIGNERS AND OWNERS. THE CHARM LIES IN ITS EXTREME TRANSPARENCY AND LIGHTING. LARGE GLASS COMBINED WITH SLIM PROFILES CAN BRING AN UNPARALLELED BROAD VIEW, MAKING THE BUILDING AND THE SURROUNDING ENVIRONMENT INTEGRATED.

GRAND SLIM PANORAMIC SLIDING SYSTEM IS THE FIRST PANORAMIC SLIDING SYSTEM WITH RICH CONFIGURATIONS PROVIDED BY THE COMPANY IN THE INDUSTRY. A WIDE RANGE OF OPENING TYPES PROVIDE A VARIETY OF APPLICATION SOLUTIONS TO MEET HIGHER REQUIREMENTS FOR DESIGN, SAFETY, QUALITY AND FUNCTION. IT ADAPTS FUNCTIONS AND PERFORMANCE CHARACTERISTICS FOR DOOR AND WINDOW PROJECTS, GIVING DESIGNERS MORE ROOM TO DISPLAY WHEN PLANNING AND DESIGNING. IN TERMS OF THE DIVERSITY OF PRODUCT DESIGN, THE COMPANY HAS ALWAYS BEEN AT THE FOREFRONT OF THE INDUSTRY.

GRAND SLIM PANORAMIC SLIDING SYSTEM IS OPENING UP A NEW DESIGN STYLE AND SYSTEM CONCEPT-THE INDUSTRY'S SHORTEST 50 MM LINEAR TRACK, EXPANSION INSTALLATION TECHNOLOGY, NO PRE-EMBEDDED DRAINAGE TREATMENT AND OTHER NEW FEATURES, PROVIDING DESIGNERS AND PROCESSORS WITH MORE UNPRECEDENTED NEW ADVANTAGES.



## INNOVATIVE DOOR TECHNOLOGY

INNOVATIVE DOOR TECHNOLOGY  
FLEXIBLE CHOICE OF GLASS THICKNESS  
AND EFFICIENT PROCESSING

IN THE PAST, PANORAMIC SLIDING PRODUCTS MOSTLY USED 90-DEGREE CONNECTION AND EXTERNAL GLUING PROCESS TO THE DOOR, JUST BECAUSE THE VISIBLE SURFACE OF THE PROFILE WAS REDUCED. AS A RESULT, THE CORNER STRENGTH AND AESTHETICS WERE ALWAYS UNSATISFACTORY.

THE INNOVATIVE DOOR LEAF TECHNOLOGY OF THE GRAND SLIM PANORAMIC SYSTEM SHOWS A WHILE MAINTAINING THE 28 MM, A NEW EXTERNAL GLUE-FREE SOLUTION, WHICH SIMPLIFIES THE INSTALLATION PROCESS AND SHOWS HIGH-END DESIGN ELEMENTS; THE 45-DEGREE BEVEL ANGLE SCREW CONNECTION TECHNOLOGY HAS EFFICIENT PROCESSING AND STRENGTH GUARANTEE.

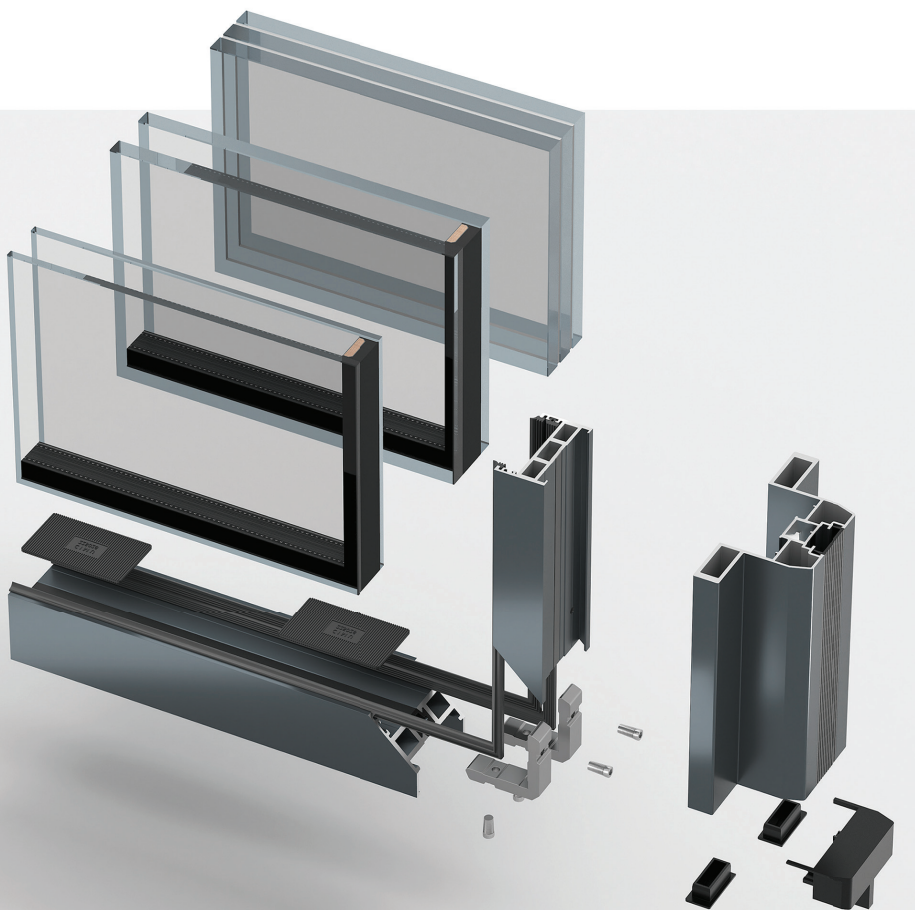

## DESIGN ADVANTAGES

THE NEW RUBBER STRIP SOLUTION GIVES THE GLASS GROOVE MAXIMUM DESIGN FREEDOM. MAXIMUM GROOVE SIZE 41 MM, AND THE GLASS AREA CAN REACH 20 M, WHICH IS IN LINE WITH THE PANORAMIC DESIGN CONDITIONS OF LARGE DOORS

THE CONTINUOUS SEALING STRIP PROVIDES EXCELLENT WATER TIGHTNESS, WITH ONLY THE SEALING GLUE STRIP EXPOSED, SMOOTH AND TIDY WITH SLIM TO ACHIEVE A FLUSH APPEARANCE FOR THE PANORAMIC DOOR LEAF.

## A PUSH-PULL SYSTEM NUMEROUS DESIGN OPTIONS

- 1 SYSTEM MODULE, 3 TRACK TYPES** GRAND SLIM VARIOUS TRACK OPTIONS ARE SUITABLE FOR DIFFERENT PROJECT REQUIREMENTS, GIVING DESIGNERS THE GREATEST DEGREE OF DESIGN FREEDOM.
- 2 SIMPLIFY SYSTEM COMPONENTS AND SIMPLIFY COSTS** FROM A TECHNICAL PERSPECTIVE, THE BIGGEST ADVANTAGE OF THE SAME MODULE IS TO REDUCE MATERIAL AND LEARNING COSTS. THE WIDTH OF THE TWO-TRACK IS 137 MM, AND THE WIDTH OF THE THREE-TRACK IS 206 MM. EXCEPT FOR THE TRACK, THE OTHER STRUCTURES OF THE SYSTEM ARE THE SAME.
- 3 EYE-CATCHING TRACK FEATURES** GSS138 TRACK DESIGN HAS EXTREMELY HIGH PASSABILITY AND CONVENIENCE. THE THREE TYPES OF TRACKS CAN MAKE THE THRESHOLD STRUCTURE MEET THE REQUIREMENTS OF BARRIER-FREE ACCESS.

## PROCESSING ADVANTAGES

SIMPLIFY THE ON-SITE FRAME INSTALLATION PROCESS, ESPECIALLY SAVE COSTS WHEN TRANSPORTING LARGE UNITS;

EFFICIENT AND RELIABLE 45-DEGREE ANGLE ASSEMBLY, UNIFIED PROCESSING TECHNOLOGY NOT ONLY GREATLY IMPROVES THE STRENGTH AND AESTHETICS, BUT ALSO PROVIDES A RELIABLE PROCESSING PROCESS, REDUCES THE NUMBER OF COMPONENTS, AND MINIMIZES STORAGE PRESSURE.



50MM LOW RAIL (LINEAR TRACK)



40MM STANDARD RAIL



**THE EMBEDDED SEALED FRAME WITH FULLY HIDDEN DESIGN ALLOWS FOR SEAMLESS CONNECTION BETWEEN INDOOR AND OUTDOOR**

GRAND SLIM PROVIDES TWO SOLUTIONS THAT CAN MAKE THE FRAME AND THE WALL TRANSITION FLUSH. THE CONSTRUCTION PARAMETERS ARE THE SAME AND ONLY SIMPLE PRE-EMBEDDED CONDITIONS ARE REQUIRED.

THE LOCKING HARDWARE OF THE STANDARD LIGHT-ENTRY SOLUTION IS ON THE FRAME SIDE. THE LIGHT-ENTRY HAS A 14 MM SLIM REINFORCED PROFILE. THE PROTRUDING PART CAN ACT AS A POWER HANDLE, ALLOWING USERS TO MOVE LARGE SLIDING DOORS EFFORTLESSLY.

THE LOCKING HARDWARE OF THE HIDDEN LIGHT-ENTRY SOLUTION IS ON THE HOOK SIDE, SO THAT THE LIGHT-ENTRY PROFILE IS COMPLETELY HIDDEN IN THE FRAME. THE "FULL SCREEN" FEATURE ALLOWS THE ENTIRE DOOR TO ONLY EXPOSE THE TRANSPARENT GLASS AND THE HOOK PART, PROVIDING A MORE EXTREME VISUAL EXPERIENCE.

BOTH SOLUTIONS HAVE SEALING STRIPS AND CENTRAL RUBBER STRIPS. AFTER THE DOOR LEAF IS LOCKED, IT IS TIGHTLY ATTACHED TO THE SLIDING PROFILE TO SEAL THE GAP BETWEEN THE SLIDING DOOR AND THE OUTER FRAME. IN ADDITION TO PROVIDING THE FUNCTION OF LIMITING AND ANTI-COLLISION, IT ALSO PLAYS A COMPLETE AIRTIGHTNESS AND WATERTIGHTNESS.

**FRAME SIDE LOCK METHOD**

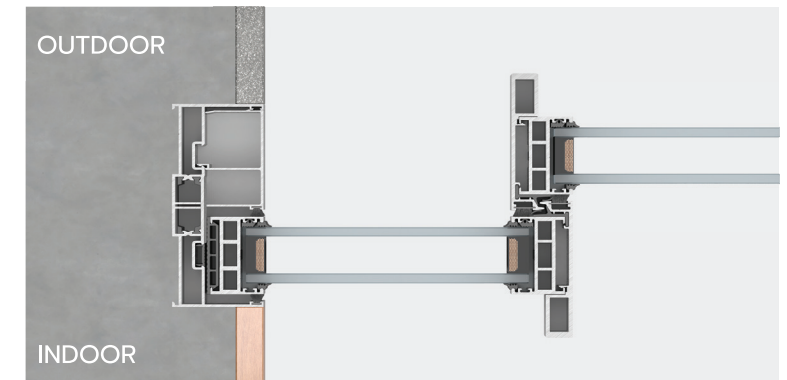

**HOOK SIDE LOCK METHOD**

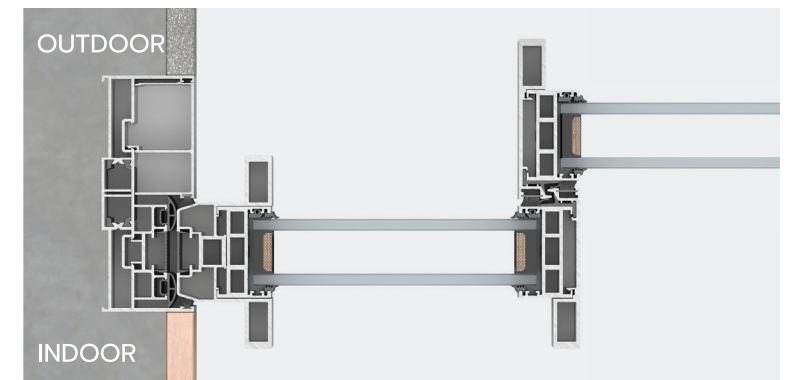

# BEAUTY AND SLIM HOOKS COEXIST

## SLIM LIFT FOR ALL PROJECT REQUIREMENTS

THE VISIBLE SURFACE OF THE PANORAMIC DOOR FRAME CAN BE COMPLETELY HIDDEN IN THE CEILING AND FLOOR, THE FIXED AND OPENING LEAF ARE DIVIDED BY EXTREMELY SLIM HOOKS. THIS MEANS THAT THE HOOK POSITION NEEDS TO MEET THE ULTIMATE DESIGN AND FUNCTIONAL REQUIREMENTS.

THANKS TO THE 28 MM EXTREMELY NARROW LEAF DESIGN, AFTER THE INTEGRATED DECORATIVE COVER, THE WIDEST VISIBLE SURFACE OF THE GRAND SLIM HOOK TYPE IS A 32 MM REINFORCED FLUSH HOOK, WHILE THE SMALL HOOK WITH NON-FLUSH FINISH IS ONLY 14 MM, WHICH IS BEAUTIFUL AND THIN WHILE HAVING A HUMANIZED HANDLE FUNCTION.

THE GRAND SLIM PANORAMIC SYSTEM HAS A WEALTH OF HOOK SYSTEM SOLUTIONS THAT CAN BE FLEXIBLY CONFIGURED FOR ANY APPLICATION. THE SYSTEM USES THE SAME PROFILES AND COMPONENTS TO A LARGE EXTENT TO MEET ALL REQUIREMENTS : FUNCTION, STRENGTH, AND AESTHETICS.

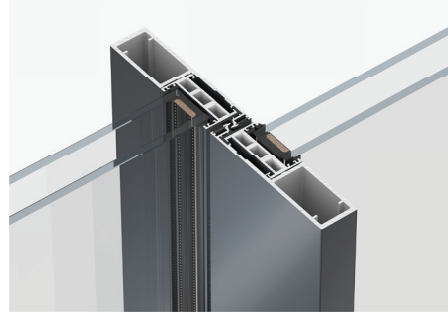

**32MM REINFORCED HOOK**

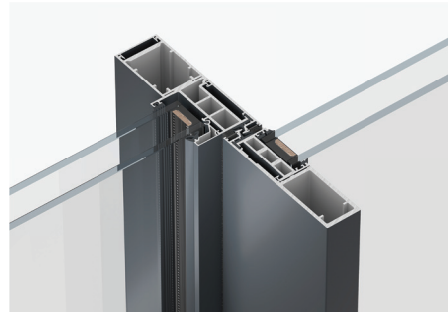

**32MM REINFORCED HOOK (FIXED WINDOW)**

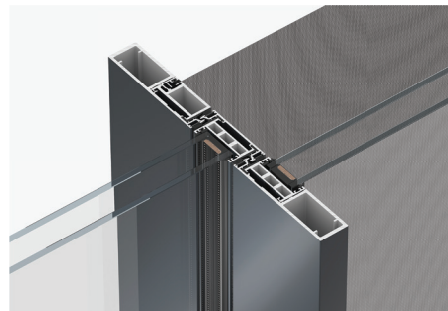

**32MM REINFORCED HOOK (THREE-TRACK WITH SCREEN WINDOW)**

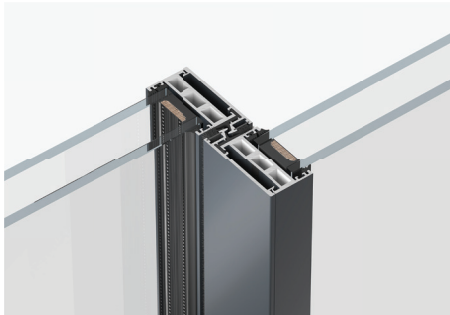

**STANDARD HOOK AND STUB**

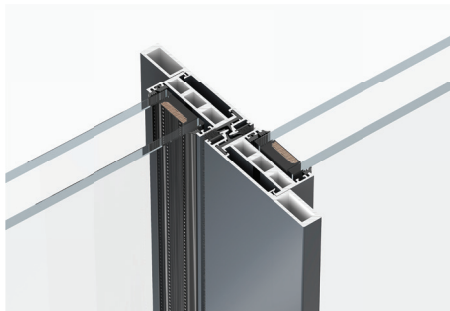

**14MM REINFORCED HOOK AND STUB**

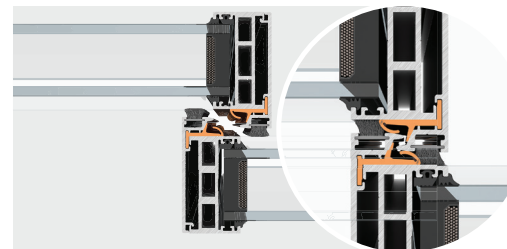

**PUSH-PULL STATUS**

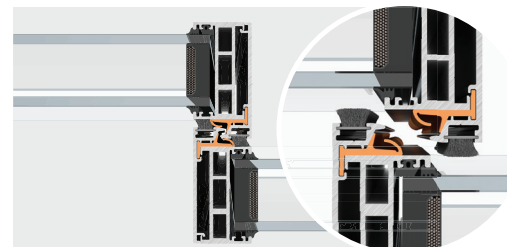

**CLOSED STATUS**

COMPLETE SEAL DESIGN

**COMPLETELY SEALED DESIGN  
PERFECT COMBINATION OF PRECISION  
TECHNOLOGY AND ULTIMATE APPEARANCE**

THE GRAND SLIM HOOK AND INTERNAL SEALING SOLUTION IS COMPOSED OF COMPLETELY SOFT AND HARD COMPOSITE TYPE, SPACERS AND MULTI-CHANNEL HAIR STRIP.

THE SPACERS MADE OF NEW MATERIALS HAVE THE THREE-IN-ONE PROPERTIES OF ANTI-COLLISION, HEAT INSULATION AND SEALING STRIPS. THIS NOVEL DESIGN ALLOWS THE HOOK AND STILE TO FIT TIGHTLY. AFTER CLOSING THE DOOR LEAF, THE Z-SHAPED PLUG-IN STRUCTURE ENSURES THE THERMAL AND SEALING CAPABILITIES OF THE HOOK AND STILE WITHIN AN EXTREMELY NARROW 32 MM VISIBLE SURFACE.

# 50MM LOW RAIL (LINEAR TRACK)

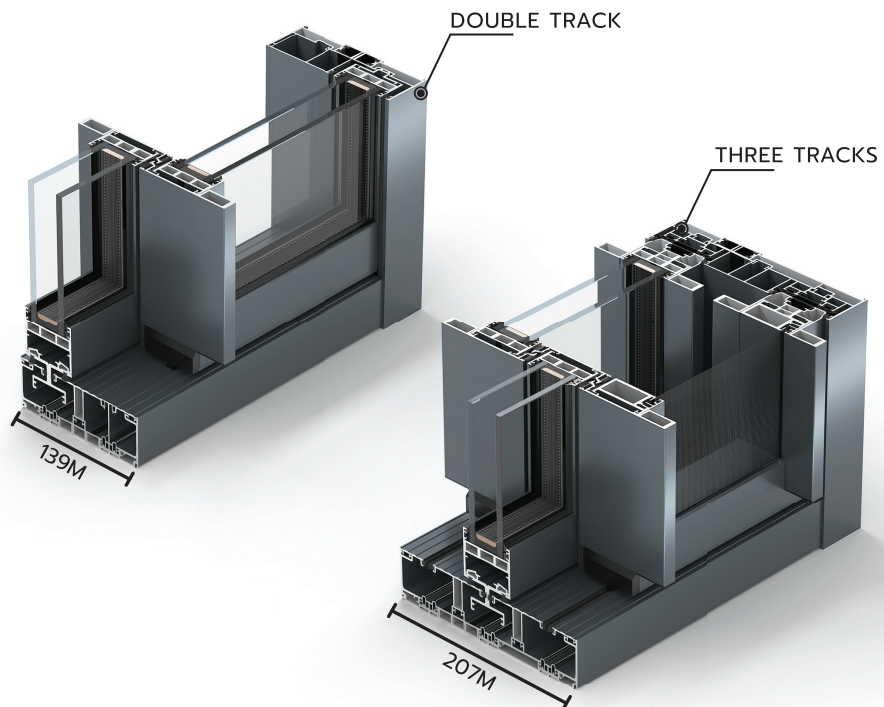

## THE PANORAMIC DESIGN 50MM ULTRA-LOW LINEAR TRACK

GRAND SLIM PANORAMIC SLIDING DOOR PROVIDES THE INDUSTRY WITH AN UNPRECEDENTED LOW LINEAR RAIL DOOR SILL SOLUTION FOR THE FIRST TIME. THE SOLUTION INCLUDES A COVER PLATE AND A DRAINAGE TROUGH WITH A HEIGHT OF ONLY 50 MM. WHILE RETAINING CONVENIENT PASSABILITY, THE ONE-PIECE DESIGN OF THE INNER ARM ALLOWS THE WATER COLLECTION TROUGH OF THE TRACK TO BE APPROPRIATELY RAISED, AND THE BASIC WATERTIGHT PERFORMANCE OF THE PANORAMIC SLIDING DOOR IS GUARANTEE.

THE NEW FLUSH THRESHOLD NOT ONLY IMPROVES COMFORT AND FACILITATES ENTRY AND EXIT, BUT ALSO PERFECTLY COMBINES DESIGN-ORIENTED PERSONALIZED NEEDS AND ON-SITE CONSTRUCTION REQUIREMENTS. IT NO LONGER REQUIRES COMPLEX AND INSTALLATION CONDITIONS, AND IS NO DIFFERENT FROM TRADITIONAL BALCONY CORRIDOR DOORS.

THE INTEGRATION OF PANORAMIC DESIGN AND LINEAR TRACKS MAKES THE EASILY APPLIED TO COMMERCIAL RESIDENCES A REALITY!

## SMOOTH CONNECTION BETWEEN INSIDE AND OUTSIDE EXTENDED LIVING SPACE

THE 50 MM ULTRA-LOW LINEAR TRACK ALSO ALLOWS THE GRAND SLIM PANORAMIC DOOR TO BE EQUIPPED WITH A BARRIER-FREE ENTRY AND EXIT THRESHOLD DESIGN, WHICH ONLY REQUIRES THE ADDITION OF SIMPLE MATERIAL ACCESSORIES AND PRE-CONTROL OF CONSTRUCTION CONDITIONS.

AS A NEW BUILDING SOLUTION, THE ZERO-LEVEL HEIGHT DIFFERENCE PRE-BURIED TRACK PROFILE, WITH A WATER TANK AND DRAINAGE CHANNEL, NOT ONLY SEAMLESSLY CONNECTS THE INDOOR AND OUTDOOR FLOORS, BUT ALSO GREATLY IMPROVES THE USER'S COMFORT AND THE WATERTIGHTNESS OF THE THRESHOLD.

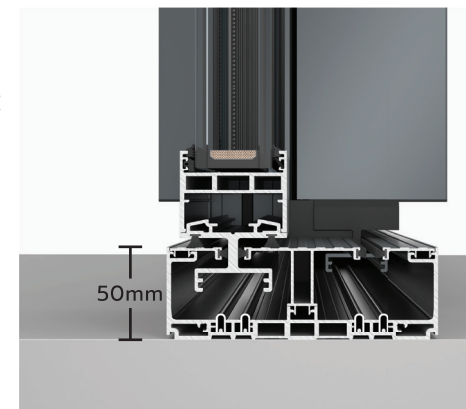

PANORAMIC  
SLIDING WINDOW

# 40MM STANDARD RAIL

## SIMPLE CONSTRUCTION FOR PANORAMIC DESIGN EXTREMELY ECONOMICAL

IN ADDITION TO CONFIGURING A UNIQUE LINEAR RAIL STRUCTURE FOR PANORAMIC DOOR USERS, THE COMPANY ALSO RETAINS THE CLASSIC BASIC 40 MM VISIBLE SURFACE LOWER RAIL SOLUTION.

INNER WATER RETAINING, CENTRAL SEALING PLUG-IN, OUTER SLOPE DRAINAGE SURFACE - SIMPLE AND EFFICIENT PROCESSING, INSTALLATION AND COST-EFFECTIVE FEATURES, OTHER STRUCTURAL OR APPEARANCE FEATURES ARE NO DIFFERENT FROM THE ULTIMATE GRAND SLIM LINEAR RAIL TYPE.

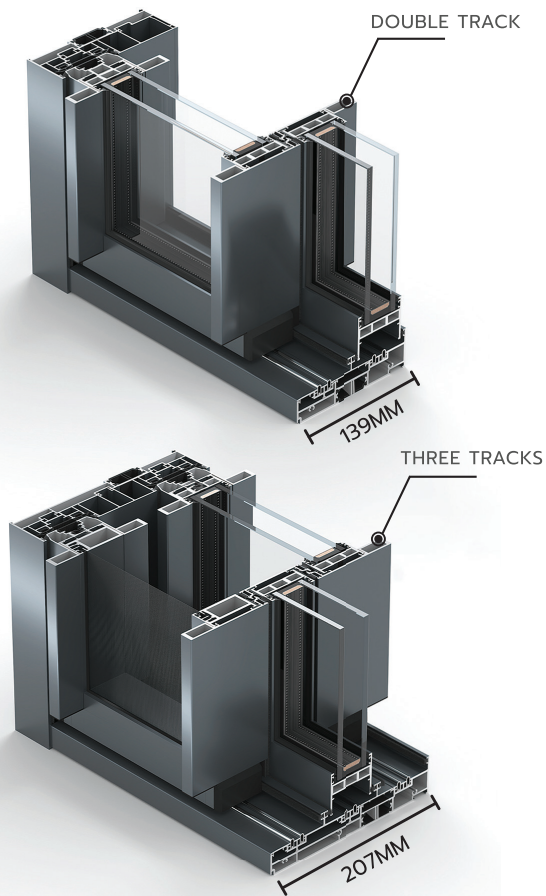

**EXPANDED FUNCTIONAL OPTIONS ALLOW PANORAMIC DESIGN TO BE MORE POWERFUL**

GRAND SLIM PROVIDES MANY BASIC OPENING TYPES, SUCH AS ONE FIXED AND ONE MOVABLE, MULTIPLE FIXED AND ONE MOVABLE, THREE MOVABLE, THREE-TRACK AND MULTIPLE WITH SCREENS, ETC., TO MEET MOST PROJECT APPLICATIONS.

AND THE SPECIAL EXTENDED FUNCTIONS: **DOUBLE-LEAF, CORNER OPENING, MOTOR DRIVE TECHNOLOGY, ETC.** CAN PROVIDE DESIGNERS WITH MORE ROOM TO DISPLAY, SO AS TO BRING OUT MORE POSSIBILITIES OF ARCHITECTURAL DESIGN AND MEET PERSONALIZED NEEDS.

FINISHING TREATMENT OF **DOUBLE DOOR**

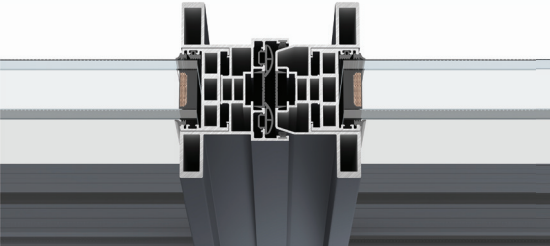

FINISHING TREATMENT OF **CORNER DOORS**

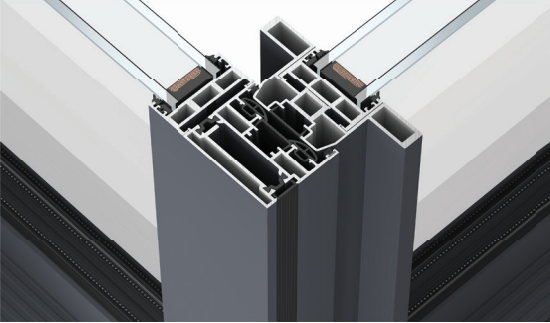

**A NEW GENERATION OF PANORAMIC DOOR HARDWARE COMBINE HIGH QUALITY WITH VERSATILITY**

IN THE DEVELOPMENT OF THE NEW HARDWARE SYSTEM, THE COMPANY HAS A LOT OF IDEAS AND NEEDS OF USERS AND PROCESSORS TO SOLVE THE PROBLEMS OF LOCKING AND LOAD-BEARING OF MOST LARGE-SIZED PANORAMIC SLIDING DOORS. WITH TWO FRAME SOLUTIONS, STANDARD AND HIDDEN, **GRAND SLIM** ALSO PROVIDES **FLEXIBLE HARDWARE** DESIGN OPTIONS.



STAINLESS STEEL LOCK

- WRENCH LOCK
- ERROR-PREVENTING OPERATOR
- STAINLESS STEEL ANTI-THEFT LOCK PLATE
- INTEGRATED TRANSMISSION

**STANDARD LIGHT LOCK (INDOOR SINGLE-SIDED OPERATION)**

UNDER STANDARD CONDITIONS, THE HARDWARE LOCK OPERATES **SMOOTHLY ON THE FRAME STRIP** FITS INSIDE THE HANDLE PROFILE, WHICH HELPS TO MAKE IT EASIER TO CONVENIENTLY OPERATE THE SLIDING MANUALLY. NEW ONE-PIECE STYLE, THE ACTUATOR STRUCTURE PRESENTS A MORE REFINED AND ELEGANT APPEARANCE, AND THE LOCK BODY IT IS COMPLETELY FLUSH WITH THE SURFACE OF THE PROFILE, ONLY TO PREVENT MISUSE OF THE DEVICE.

THE ACTUATOR IS EMBEDDED WITH A STAINLESS STEEL LOCK HOLE, WHICH IS INCOMPATIBLE WITH THE FRAME AFTER CLOSING. THE STAINLESS STEEL HOOK-SHAPED LOCK FORMS THE LOCKING POINT, ALLOWING THE PANORAMIC SLIDING DOOR TO SECURITY IS SIGNIFICANTLY IMPROVED.

**STANDARD LIGHT WITH KEY LOCK (INDOOR AND OUTDOOR DOUBLE-SIDED OPERATION)**

THE SINGLE-SIDED LOCK VERSION BASED ON UPGRADED IN STRUCTURE, AND IS DEVELOPED FOR COMMERCIAL DOORS OR GARDEN ENTRANCE DOORS WITH HIGH SECURITY REQUIREMENTS. WITH THE COMBINATION OF MECHANICAL COMPONENTS AND SPECIAL GLASS, THE SYSTEM CAN BE UPGRADED TO A HIGHER ANTI-THEFT LEVEL.

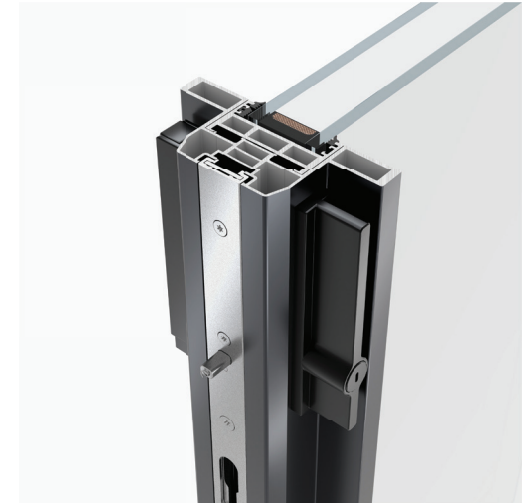

**HOOK LOCK (INDOOR SINGLE-SIDED OPERATION)**

WHEN THE USER CHOOSES A LOCKING SOLUTION FOR HIDDEN LIGHT, THE HARDWARE COMPONENTS ARE DEPLOYED AT THE HOOK FIXTURE POSITION. THE HOOK FIXTURE CAN BE INSTALLED BY SIMPLY PROCESSING IT. IT IS EQUIPPED WITH A **DOUBLE HOOK LOCK SEAT** DESIGN. UNDER THE BASIC LOCKING, THIS FULLY HIDDEN FRAME CAN ACHIEVE A MORE EXTREME FIELD OF VIEW.



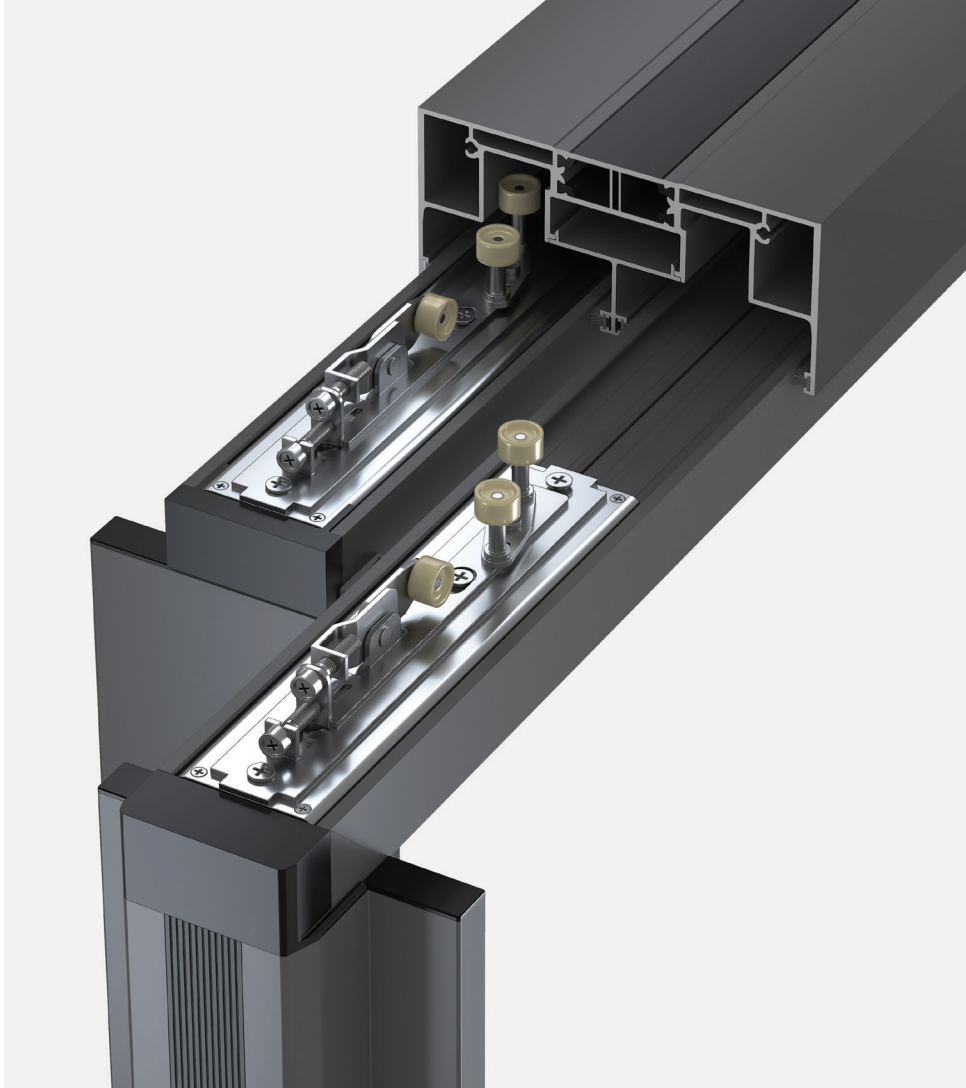

CLAMP TYPE HIGH BEARING BLOCK

**CLAMPED HIGH LOAD BEARING PULLEY SET**

 MAXIMUM LOAD BEARING  
1000KG /SLIDING

GRAND SLIM HAS A NEWLY OPTIMIZED **HIGH-LOAD-BEARING STEEL PULLEY BLOCK**, WHICH IS DESIGNED FOR MATCHING APPLICATIONS WITH DOORS OF DIFFERENT SIZES AND WEIGHTS. THE CLAMPING INSTALLATION AND FLAT CROSS-SECTION CHARACTERISTICS ALLOW THE PULLEY BLOCK TO BE STACKED ALMOST INFINITELY. THEREFORE, THE ALLOWABLE WEIGHT OF A SINGLE DOOR OF **GRAND SLIM** CAN REACH **1000KG (800KG FOR ELECTRIC DOORS)**, AND THE MAXIMUM WIDTH OF THE SLIDING DOOR CAN REACH 6 METERS (HEIGHT UP TO 3 METERS) AND THE MAXIMUM HEIGHT CAN REACH 5 METERS (WIDTH UP TO 3 METERS).

THESE PERFORMANCE CHARACTERISTICS EASILY MEET THE APPLICATION CONDITIONS OF MOST SIZES OF SLIDING DOORS, ALLOWING USERS TO **EFFORTLESSLY CONTROL THE OPENING AND CLOSING OF WINDOWS**.



**ADJUSTABLE ANTI-TRIP GUIDE WHEEL**

CONSIDERING THE TWO SAFETY FACTORS OF ANTI-THEFT AND ANTI-TYPHOON, **GRAND SLIM** IS ALSO EQUIPPED WITH UPPER RAIL GUIDE WHEELS THAT CAN BE ADJUSTED IN HEIGHT AND LEFT AND RIGHT.

THE LEFT AND RIGHT LIMIT WHEELS ARE ADJUSTABLE TO ADAPT TO THE CHANGES IN TRACK TOLERANCE AND SLIDE MORE SMOOTHLY IN THE GUIDE GROOVE, WHILE THE HEIGHT-ADJUSTABLE WHEELS CAN PUSH UPWARD AGAINST THE PROFILE GROOVE SURFACE AND COOPERATE WITH THE BITE OF THE LOWER PULLEY TO PREVENT LARGE-SIZE SLIDING FROM SWINGING AND FALLING OFF EASILY DUE TO WIND PRESSURE AND HUMAN INFLUENCE.

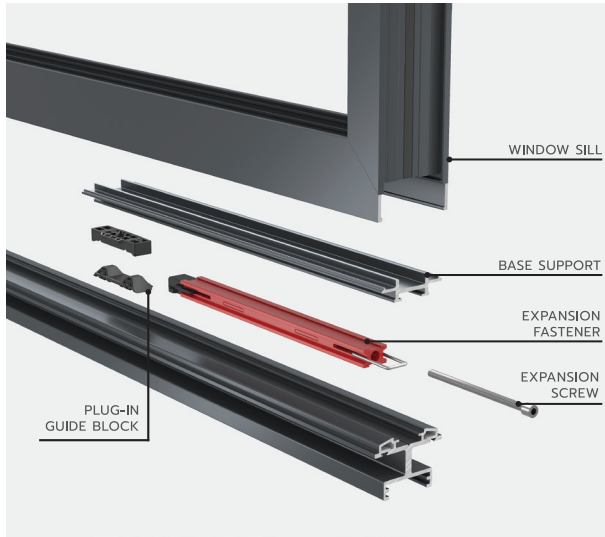

## REVOLUTIONARY RAIL TECHNOLOGY EFFICIENT INSTALLATION AND MAINTENANCE

EXISTING LINEAR RAIL SLIDING WINDOWS OR DOORS HAVE SHORTCOMINGS IN WORKSHOP PROCESSING AND ASSEMBLY, ON-SITE INSTALLATION, OWNER HYGIENE AND PRODUCT MAINTENANCE. ESPECIALLY FOR SUPER-LARGE DOORS, THE ENTIRE PROCESS OF PRODUCT PROCESSING, INSTALLATION, AND MAINTENANCE DURING THE LIFE CYCLE NEEDS TO BE FULLY CONSIDERED.

DIFFERENT FROM THE ROUGH INSTALLATION AND DISASSEMBLY OF CONVENTIONAL LINEAR RAILS, THE NOVEL INSTALLATION COMPONENT TECHNOLOGY OF GRAND SLIM CONSISTS OF EXPANSION FASTENERS, GUIDES, AND EXPANSION SCREWS.

AT THE CONSTRUCTION SITE, YOU ONLY NEED TO LIFT THE DOOR LEAF, INSERT THE EXPANSION PIECE, SCREW IN THE SCREWS, AND THE INSTALLATION IS COMPLETE! GREATLY IMPROVE THE INSTALLATION EFFICIENCY AND FINISHED PRODUCT COMPLETION ACCURACY.

THE TRACK PEDALS ARE UNIFORMLY PRE-ASSEMBLED IN THE WORKSHOP, AND THERE IS NO NEED TO DISASSEMBLE THEM REPEATEDLY ON SITE. THE PEDAL ENDS ARE DISCONNECTED BY THE END PLUGS, AND THE PEDALS CAN BE EASILY REMOVED.

THE SIMPLE PEDAL MODULE COMBINED WITH THE LINEAR RAIL INSTALLATION COMPONENTS MAKES IT POSSIBLE TO EASILY INSTALL, DISASSEMBLE, CLEAN AND MAINTAIN THE LINEAR RAIL. THIS SET OF PRECISE, SAFE AND EFFICIENT LINEAR RAIL INSTALLATION TECHNOLOGY HAS BEEN TECHNICALLY VERIFIED AND MARKET RECOGNIZED ON THE SLIDING WINDOW.

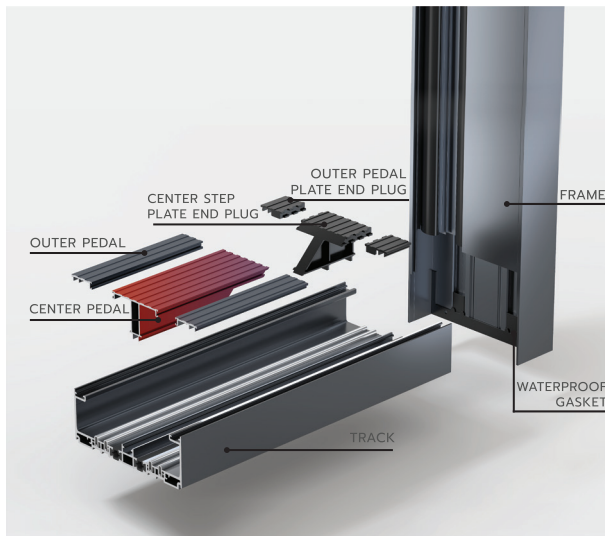

## POPULARIZING HIGH-END PRODUCTS COST-EFFECTIVE AND HIGH-PERFORMANCE DESIGN

PANORAMIC DESIGN, LARGE SPECIFICATIONS, SLIM FACADES, THESE HIGH-END TERMS AND PRODUCT AREAS HAVE RECEIVED MUCH ATTENTION IN RECENT YEARS. HOWEVER, MANY TECHNICAL DETAILS AND APPLICATIONS ARE STILL DIFFICULT FOR EXPERIENCED MANUFACTURERS OR TECHNICIANS, AND EVEN MORE DIFFICULT FOR ORDINARY TERMINAL DEALERS. WE SEEM TO NEED SOME DIMENSIONALITY REDUCTION THINKING TO ENABLE CUSTOMERS TO IMPORT DESIGN CONCEPTS.

**GRAND SLIM** IS THE FIRST TIME THAT THE COMPANY HAS INTEGRATED THE MAXIMUM ECONOMIC BENEFITS AND **HIGH-PERFORMANCE DESIGN INTO THE PANORAMIC SYSTEM**. FLEXIBLE TRACK MODULES, EFFICIENT PROCESSING TECHNOLOGY, AND A WIDE RANGE OF OPENING TYPES PROVIDE USERS WITH GREATER APPLICATION FREEDOM. THE 50 MM ULTRA-LOW LINEAR TRACK CONCEPT PROPOSED BY THE INDUSTRY FOR THE FIRST TIME IS DEVELOPED FOR THE PURPOSE OF BEING EASILY APPLIED TO COMMERCIAL HOUSING AND PROJECTS WITHOUT PRE-BURIED CONSTRUCTION CONDITIONS THROUGH PARTICULARLY SIMPLE PROCESSING AND CONSTRUCTION.

THE COMPANY ACTIVELY LEVERAGES ITS TECHNICAL ADVANTAGES AND INDUSTRY EXPERIENCE IN THE HIGH-END FIELD TO MAKE THE GRAND SLIM PANORAMIC PUSH-PULL SYSTEM MORE IN LINE WITH THE ACTUAL APPLICATION NEEDS OF THE RETAIL MARKET.



